

- 1
- 2
- 3
- 4
- 5
- 6
- 7
- 8
- 9
- 10
- 11
- 12
- 13
- 14
- 15
- 16
- 17
- 18

**LEVIER**

Alliage de zinc moulé sous pression avec revêtement en résine époxy, finition sablée mate.

**EXÉCUTIONS STANDARDS**

Vis de retenue avec empreinte en forme d'étoile à six branches pour serrage avec outil TORX®\* (voir communication ci-jointe). Ressort de rappel en acier. Élément de serrage et vis de retenue en acier bruni.

- GN 300 (d1): trou fileté.
- GN 300 (d1 - I2): vis filetée.

**CARACTÉRISTIQUES ET APPLICATIONS**

Particulièrement indiquée quand l'angle de manœuvre du levier est limité pour des raisons d'encombrement.

**INSTRUCTIONS D'EMPLOI**

Pour la reprise en cours de serrage soulever le levier pour désengager la denture de l'élément de serrage et le remettre dans la position de départ. En lâchant le levier, le ressort de rappel remet automatiquement la denture en prise.

Dans le cas où le levier ne peut pas effectuer un tour complet de 360°, le vissage de l'élément de serrage peut être réalisé en agissant sur la vis avec empreinte en forme d'étoile à six branches (après avoir désengagé le levier).

**EXÉCUTIONS SPÉCIALES SUR DEMANDE**

- Levier dans des couleurs différentes
- Levier chromé.
- Élément de serrage avec filetages et longueurs différents.

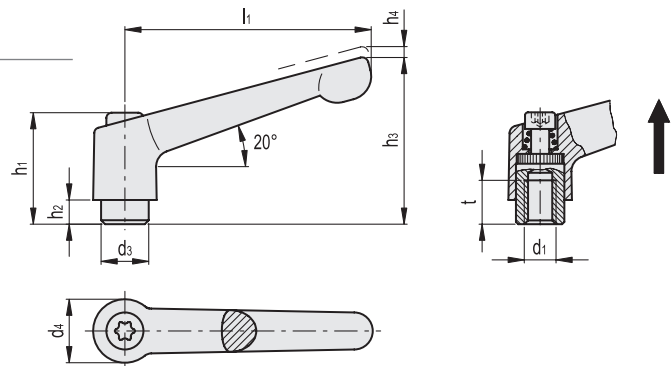

\* Complétez avec l'index de la couleur du levier (SW, OS, GR)

- SW  
 RAL9005
- OS  
 RAL2004
- GR  
 RAL7031

**GN 300 (d1)**

Code SW	Code OS	Code GR	Description	l1	d1	d3	d4	h1	h2	h3	h4	tmin	⚖️
GN.15801	GN.15802	-	GN 300-30-M3*	30	M3	10	13	24.5	4	31	3.5	7	15
GN.15806	GN.15807	-	GN 300-30-M4*	30	M4	10	13	24.5	4	31	3.5	7	15
GN.15811	GN.15812	-	GN 300-30-M5*	30	M5	10	13	24.5	4	31	3.5	7	15
GN.15816	GN.15817	-	GN 300-30-M6*	30	M6	10	13	24.5	4	31	3.5	7	15
GN.16101	GN.16102	GN.16104	GN 300-45-M5*	45	M5	10	13	24.5	4	35	3.5	9	34
GN.16111	GN.16112	GN.16114	GN 300-45-M6*	45	M6	10	13	24.5	4	35	3.5	9	33
GN.16121	GN.16122	GN.16124	GN 300-63-M6*	63	M6	13.5	17.5	31	6.5	45	4	11	76
GN.16131	GN.16132	GN.16134	GN 300-63-M8*	63	M8	13.5	17.5	31	6.5	45	4	11	74
GN.16141	GN.16142	GN.16144	GN 300-78-M8*	78	M8	16	21	36	8	55	4	14	123
GN.16151	GN.16152	GN.16154	GN 300-78-M10*	78	M10	16	21	36	8	55	4	17	194
GN.16161	GN.16162	GN.16164	GN 300-92-M10*	92	M10	19	24	43	11	65	4	17	194
GN.16171	GN.16172	GN.16174	GN 300-92-M12*	92	M12	19	24	43	11	65	4	17	171
GN.16181	GN.16182	GN.16184	GN 300-108-M12*	108	M12	23	30	50.5	12	76	5	22	306
GN.16185	GN.16186	GN.16188	GN 300-108-M14*	108	M14	23	30	50.5	12	76	5	22	298
GN.16191	GN.16192	GN.16194	GN 300-108-M16*	108	M16	23	30	50.5	12	76	5	22	306

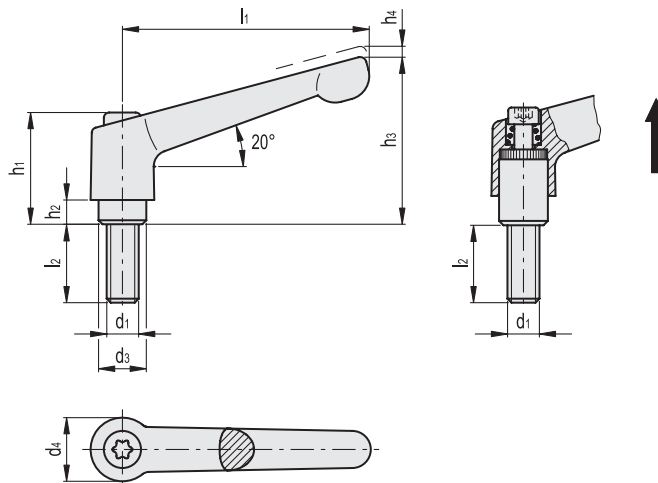

\* Complétez avec l'index de la couleur du levier (SW, OS, GR)

SW  
RAL9005

OS  
RAL2004

GR  
RAL7031

### GN 300 (d1 - l2)

Code SW	Code OS	Code GR	Description	l1	d1	d3	d4	h1	h2	h3	h4	l2	⚖
GN.15831	GN.15832	-	GN 300-30-M3-6-*	30	M3	10	13	24.5	4	31	3.5	6	26
GN.15836	GN.15837	-	GN 300-30-M3-8-*	30	M3	10	13	24.5	4	31	3.5	8	26
GN.15841	GN.15842	-	GN 300-30-M3-10-*	30	M3	10	13	24.5	4	31	3.5	10	26
GN.15846	GN.15847	-	GN 300-30-M3-12-*	30	M3	10	13	24.5	4	31	3.5	12	26
GN.15851	GN.15852	-	GN 300-30-M3-16-*	30	M3	10	13	24.5	4	31	3.5	16	26
GN.15861	GN.15862	-	GN 300-30-M4-12-*	30	M4	10	13	24.5	4	31	3.5	12	27
GN.15866	GN.15867	-	GN 300-30-M4-16-*	30	M4	10	13	24.5	4	31	3.5	16	27
GN.15871	GN.15872	-	GN 300-30-M4-20-*	30	M4	10	13	24.5	4	31	3.5	20	27
GN.15876	GN.15877	-	GN 300-30-M4-25-*	30	M4	10	13	24.5	4	31	3.5	25	28
GN.15881	GN.15882	-	GN 300-30-M4-32-*	30	M4	10	13	24.5	4	31	3.5	32	28
GN.15901	GN.15902	-	GN 300-30-M5-12-*	30	M5	10	13	24.5	4	31	3.5	12	28
GN.15906	GN.15907	-	GN 300-30-M5-16-*	30	M5	10	13	24.5	4	31	3.5	16	28
GN.15911	GN.15912	-	GN 300-30-M5-20-*	30	M5	10	13	24.5	4	31	3.5	20	29
GN.15916	GN.15917	-	GN 300-30-M5-25-*	30	M5	10	13	24.5	4	31	3.5	25	29
GN.15921	GN.15922	-	GN 300-30-M5-32-*	30	M5	10	13	24.5	4	31	3.5	32	30
GN.15926	GN.15927	-	GN 300-30-M5-40-*	30	M5	10	13	24.5	4	31	3.5	40	31
GN.15931	GN.15932	-	GN 300-30-M5-50-*	30	M5	10	13	24.5	4	31	3.5	50	32
GN.15951	GN.15952	-	GN 300-30-M6-12-*	30	M6	10	13	24.5	4	31	3.5	12	29
GN.15956	GN.15957	-	GN 300-30-M6-16-*	30	M6	10	13	24.5	4	31	3.5	16	29
GN.15961	GN.15962	-	GN 300-30-M6-20-*	30	M6	10	13	24.5	4	31	3.5	20	30
GN.15966	GN.15967	-	GN 300-30-M6-25-*	30	M6	10	13	24.5	4	31	3.5	25	31
GN.15971	GN.15972	-	GN 300-30-M6-32-*	30	M6	10	13	24.5	4	31	3.5	32	32
GN.15976	GN.15977	-	GN 300-30-M6-40-*	30	M6	10	13	24.5	4	31	3.5	40	33
GN.15981	GN.15982	-	GN 300-30-M6-50-*	30	M6	10	13	24.5	4	31	3.5	50	34
GN.16201	GN.16202	GN.16204	GN 300-45-M6-12-*	45	M6	10	13	24.5	4	35	3.5	12	36
GN.16211	GN.16212	GN.16214	GN 300-45-M6-16-*	45	M6	10	13	24.5	4	35	3.5	16	37
GN.16221	GN.16222	GN.16224	GN 300-45-M6-20-*	45	M6	10	13	24.5	4	35	3.5	20	37
GN.16231	GN.16232	GN.16234	GN 300-45-M6-25-*	45	M6	10	13	24.5	4	35	3.5	25	38
GN.16241	GN.16242	GN.16244	GN 300-45-M6-32-*	45	M6	10	13	24.5	4	35	3.5	32	40
GN.16251	GN.16252	GN.16254	GN 300-45-M6-40-*	45	M6	10	13	24.5	4	35	3.5	40	41
GN.16261	GN.16262	GN.16264	GN 300-45-M6-50-*	45	M6	10	13	24.5	4	35	3.5	50	43
GN.16271	GN.16272	GN.16274	GN 300-63-M8-16-*	63	M8	13.5	17.5	31	6.5	45	4	16	83
GN.16281	GN.16282	GN.16284	GN 300-63-M8-20-*	63	M8	13.5	17.5	31	6.5	45	4	20	84
GN.16291	GN.16292	GN.16294	GN 300-63-M8-25-*	63	M8	13.5	17.5	31	6.5	45	4	25	86
GN.16301	GN.16302	GN.16304	GN 300-63-M8-32-*	63	M8	13.5	17.5	31	6.5	45	4	32	88
GN.16311	GN.16312	GN.16314	GN 300-63-M8-40-*	63	M8	13.5	17.5	31	6.5	45	4	40	91
GN.16321	GN.16322	GN.16324	GN 300-63-M8-50-*	63	M8	13.5	17.5	31	6.5	45	4	50	93
GN.16331	GN.16332	GN.16334	GN 300-63-M8-63-*	63	M8	13.5	17.5	31	6.5	45	4	63	98



- 1
- 2
- 3
- 4
- 5
- 6
- 7
- 8
- 9
- 10
- 11
- 12
- 13
- 14
- 15
- 16
- 17
- 18

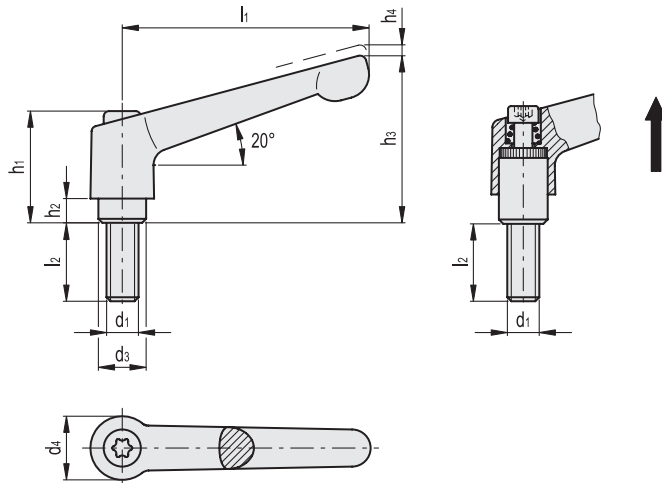

\* Complétez avec l'index de la couleur du levier (SW, OS, GR)

SW  
 RAL9005

OS  
 RAL2004

GR  
 RAL7031

GN 300 (d1 - l2)

Code SW	Code OS	Code GR	Description	l1	d1	d3	d4	h1	h2	h3	h4	l2	⚖️
GN.16341	GN.16342	GN.16344	GN 300-78-M10-20-*	78	M10	16	21	36	8	55	4	20	139
GN.16351	GN.16352	GN.16354	GN 300-78-M10-25-*	78	M10	16	21	36	8	55	4	25	141
GN.16361	GN.16362	GN.16364	GN 300-78-M10-32-*	78	M10	16	21	36	8	55	4	32	142
GN.16371	GN.16372	GN.16374	GN 300-78-M10-40-*	78	M10	16	21	36	8	55	4	40	146
GN.16381	GN.16382	GN.16384	GN 300-78-M10-50-*	78	M10	16	21	36	8	55	4	50	152
GN.16391	GN.16392	GN.16394	GN 300-78-M10-63-*	78	M10	16	21	36	8	55	4	63	159
GN.16401	GN.16402	GN.16404	GN 300-78-M10-80-*	78	M10	16	21	36	8	55	4	80	166
GN.16601	GN.16602	GN.16604	GN 300-78-M12-25-*	78	M12	16	21	36	8	55	4	25	145
GN.16611	GN.16612	GN.16614	GN 300-78-M12-32-*	78	M12	16	21	36	8	55	4	32	150
GN.16621	GN.16622	GN.16624	GN 300-78-M12-40-*	78	M12	16	21	36	8	55	4	40	156
GN.16631	GN.16632	GN.16634	GN 300-78-M12-50-*	78	M12	16	21	36	8	55	4	50	163
GN.16641	GN.16642	GN.16644	GN 300-78-M12-63-*	78	M12	16	21	36	8	55	4	63	171
GN.16651	GN.16652	GN.16654	GN 300-78-M12-80-*	78	M12	16	21	36	8	55	4	80	183
GN.16411	GN.16412	GN.16414	GN 300-92-M12-25-*	92	M12	19	24	43	11	65	4	25	212
GN.16421	GN.16422	GN.16424	GN 300-92-M12-32-*	92	M12	19	24	43	11	65	4	32	217
GN.16431	GN.16432	GN.16434	GN 300-92-M12-40-*	92	M12	19	24	43	11	65	4	40	222
GN.16441	GN.16442	GN.16444	GN 300-92-M12-50-*	92	M12	19	24	43	11	65	4	50	229
GN.16451	GN.16452	GN.16454	GN 300-92-M12-63-*	92	M12	19	24	43	11	65	4	63	239
GN.16461	GN.16462	GN.16464	GN 300-92-M12-80-*	92	M12	19	24	43	11	65	4	80	250
GN.16471	GN.16472	GN.16474	GN 300-108-M16-32-*	108	M16	23	30	50.5	12	76	5	32	365
GN.16481	GN.16482	GN.16484	GN 300-108-M16-40-*	108	M16	23	30	50.5	12	76	5	40	376
GN.16491	GN.16492	GN.16494	GN 300-108-M16-50-*	108	M16	23	30	50.5	12	76	5	50	388
GN.16501	GN.16502	GN.16504	GN 300-108-M16-63-*	108	M16	23	30	50.5	12	76	5	63	407
GN.16511	GN.16512	GN.16514	GN 300-108-M16-80-*	108	M16	23	30	50.5	12	76	5	80	429

Manettes indexables